

DESCRIPTION

The Curtis throttle assembly provides an analog 0-5V output proportional to throttle position for interfacing with motor speed controllers.

APPLICATION

This electronic throttle is ideal for use in material handling, golf cars, on-road and other electric vehicle applications which require a 0-5V input for speed control.

FEATURES

- Hall effect sensors and solid state MOSFET contactor drivers minimize moving parts, thereby increasing reliability and Mean Time Between Failure.
- Symmetrical throttle response in both forward and reverse directions ensures smooth, concise acceleration and deceleration in both directions.
- Minimal deadband areas at both zero and full throttle positions eliminates hesitation when beginning to accelerate or decelerate.
- Environmental protection of major components through an epoxy layer over the circuit board assures operation in harsh environmental conditions.
- Wig-wag type throttle returns the throttle to neutral for convenience and safety.
- Input polarity protection to ensure no damage occurs to the throttle if it is incorrectly wired.
- Easy to install.

SPECIFICATIONS

- Operating voltage:
13 – 58VDC
- Throttle output range:
0 to 5 Volts
- Maximum throttle output:
5.3 Volts
- Minimum throttle output:
0 Volts
- Maximum deadband at zero throttle:
10 degrees
- Maximum deadband at full throttle:
10 degrees
- Forward/Reverse current:
1.5 amp max
- Symmetrical throttle response in both directions

MODEL ET-126

DIMENSIONS mm

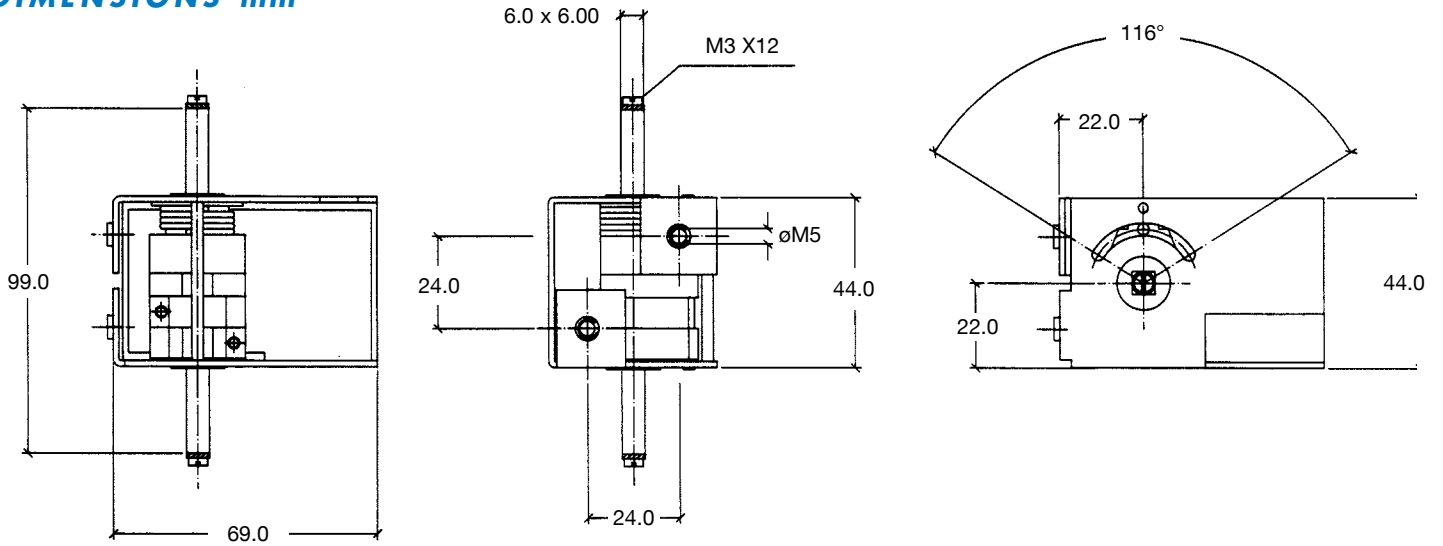

INSTALLATION

Mounting: Two M5 screws

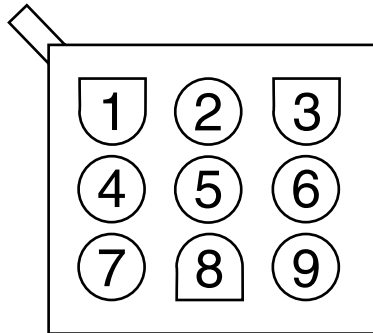

ET-126 Throttle

1	Pot Lo
2	Battery + after KSI
3	Reverse
4	Forward
5	No connect
6	No connect
7	Battery -
8	0-5V output
9	No connect

ET-126 Throttle
 AMP Mate-N-Lock Connector
 Female p/n: AMP 350720-1
 With pins: 350561-1

WARRANTY Two year limited warranty from time of delivery.